

# DB-3W Series

3W 2:1 Regulated Single & Dual output



## Features

- 8 Pin SIL
- Wide 2:1 Input Range
- Full SMD Technology
- 1600 VDC Isolation
- Continuous Short Circuit Protection
- Efficiency up to 84%
- -40 ~ 71°C Operation Temperature Range
- Plastic Case Standard, Optional Metal Case
- Remote on/off Control (Optional)

The DB 3W series is an improved version from DB 2W family. With the same package size and pin configuration, DB 3W series provide higher efficiency and higher power rating. encapsulated in 8 pin SIL package, providing input/output isolation of 1600Vdc and higher efficiency up to 84%. Available in Single in Line to save the space on board, metal case is also optional for better RFI/EMI shielding.

2:1 Wide input range and long term short circuit protection - single /dual output models are both available!

DB 3W series is a good substitution of traditional DC/DC converter 3W in DIL-24 package.

Single output models contain : 3.3V,5V,12V,15V and dual output models contain :  $\pm 5V, \pm 12V$  and  $\pm 15V$  dc

All specifications typical at  $T_a=25^\circ\text{C}$ , nominal input voltage and full load unless otherwise specified

OUTPUT SPECIFICATIONS	
Voltage Accuracy	$\pm 1\%$
Maximum Output Current	See table
Line Regulation	$\pm 0.5\%$ , max.
Load Regulation (1)	(From 25% to 100% Loading) $\pm 1\%$ , max.
Cross Regulation (Dual Output) (2)	$\pm 5\%$
Ripple & Noise (20 Mhz bandwidth)(3)	75mVpp, max.
Short Circuit Protection	Indefinite (Automatic Recovery)
Temperature Coefficient	$\pm 0.02\%/^\circ\text{C}$
Capacitive Load(4)	See table
Transient Recovery Time (5)	300us, typ.
Transient Response Deviation(5)	$\pm 3\%$ , max.

INPUT SPECIFICATIONS	
Voltage Range	See table
Start up Time (Nominal $V_{in}$ and constant resistive load)	20mS, typ.
Max. Input Current	See table
No-Load Input Current	See table
Input Filter	Capacitor
Input Reflected Ripple Current(6)	35mA pk-pk

GENERAL SPECIFICATIONS	
Efficiency	See table, typ.
I/O Isolation Voltage (tested for 3 sec)	1600Vdc
I/O Isolation Capacity	680 pF, max.
I/O Isolation Resistance	1000M Ohm, min.
Switching Frequency	100~650kHz
Humidity	95%relH
Reliability Calculated MTBF (MIL-HDBK-217 F)	>1.34 Mhrs
Safety Standard	IEC/EN 60950-1
Safety Approvals	CB
Remote on/off control(7)	
ON:	open or high impedance
OFF:	3-6mA input current (via 1K)
Off stand by input current (Nominal $V_{in}$ )	3mA max.

PHYSICAL SPECIFICATIONS	
Case Material	Non conductive black plastic
Potting Material	Epoxy (UL94V-0 rated)
Pin Material	C5191R-H Solder-coated
Weight	4.8g, typ.
Dimensions	0.86"x0.36"x0.44"

ENVIRONMENT SPECIFICATIONS	
Operating Temperature	-40°C~71°C
Maximum Case Temperature	100°C
Storage Temperature	-40°C~125°C
Cooling	Nature Convection

ABSOLUTE MAXIMUM RATINGS(8)	
These are stress ratings. Exposure of devices to any of these conditions may adversely affect long-term reliability.	
Input Surge Voltage(100ms max)	
05 Models	15 Vdc, max.
12 Models	36Vdc, max.
24 Models	50Vdc, max.
48 Models	100Vdc, max.
Soldering Temperature (1.5mm from case 10 sec. max.)	260°C max.

EMI CHARACTERISTICS		
Conducted Emissions (10)	EN55022	CLASS A
Radiated Emissions	EN55022	CLASS A
ESD	IEC 61000-4-2	Perf. Criteria A
RS	IEC 61000-4-3	Perf. Criteria A
EFT(11)	IEC 61000-4-4	Perf. Criteria A
Surge(11)	IEC 61000-4-5	Perf. Criteria A
CS	IEC 61000-4-6	Perf. Criteria A
PFMF	IEC 61000-4-8	Perf. Criteria A

The information and specifications contained in this data sheet are believed to be correct at time of publication. However, ZimTec Electronics accepts no responsibility for consequences arising from printing errors or inaccuracies. Specifications are subject to change without notice. No rights under any patent accompany the sale of any such product(s) or information contained herein.

## DB - 3W 2:1 Regulated Single & Dual output

### PART NUMBER STRUCTURE

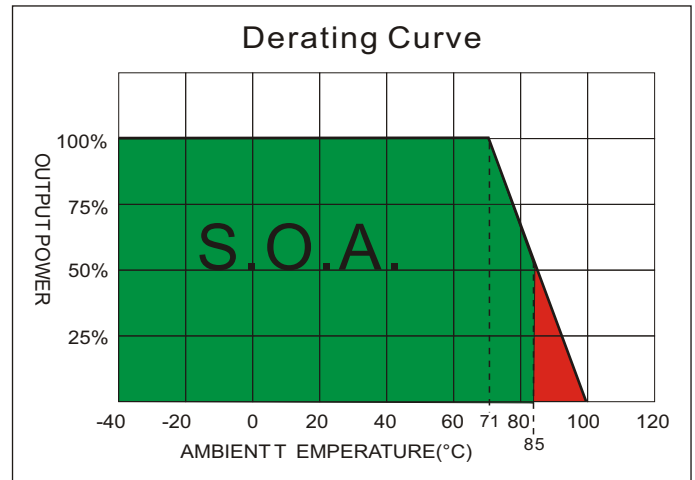
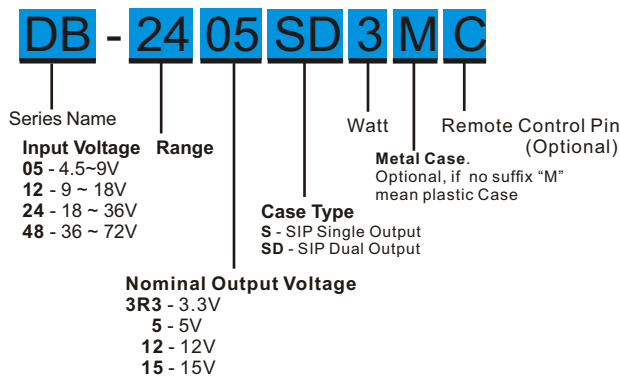

## MODEL SELECTION GUIDE

MODEL NUMBER	INPUT Voltage Range (Vdc)	INPUT Current		OUTPUT Voltage (Vdc)	OUTPUT Current		EFFICIENCY @FL(%)	Capacitor Load(μF)
		No-Load (mA)	Full Load (mA)		Min. load (mA)	Full load (mA)		
DB-0505S3C	4.5-9	70	800	5	150	600	76	1000
DB-0512S3C	4.5-9	75	750	12	62.5	250	82	470
DB-0515S3C	4.5-9	75	750	15	50	200	82	220
DB-123R3S3C	9-18	25	260	3.3	175	700	76	2200
DB-1205S3C	9-18	15	320	5	150	600	81	1000
DB-1212S3C	9-18	35	305	12	62.5	250	84	470
DB-1215S3C	9-18	35	305	15	50	200	84	220
DB-243R3S3C	18-36	15	133	3.3	175	700	74	2200
DB-2405S3C	18-36	15	160	5	150	600	79	1000
DB-2412S3C	18-36	20	156	12	62.5	250	82	470
DB-2415S3C	18-36	20	152	15	50	200	84	220
DB-483R3S3C	36-72	10	66	3.3	175	700	75	2200
DB-4805S3C	36-72	10	82	5	150	600	78	1000
DB-4812S3C	36-72	15	78	12	62.5	250	81	470
DB-4815S3C	36-72	15	78	15	50	200	81	220
DB-0505SD3C	4.5-9	90	800	±5	±75	±300	77	±470
DB-0512SD3C	4.5-9	90	760	±12	±31.25	±125	81	±220
DB-0515SD3C	4.5-9	90	750	±15	±25	±100	82	±100
DB-1205SD3C	9-18	45	320	±5	±75	±300	80	±470
DB-1212SD3C	9-18	45	308	±12	±31.25	±125	83	±220
DB-1215SD3C	9-18	45	312	±15	±25	±100	82	±100
DB-2405SD3C	18-36	20	160	±5	±75	±300	80	±470
DB-2412SD3C	18-36	20	154	±12	±31.25	±125	83	±220
DB-2415SD3C	18-36	20	154	±15	±25	±100	83	±100
DB-4805SD3C	36-72	15	82	±5	±75	±300	78	±470
DB-4812SD3C	36-72	20	80	±12	±31.25	±125	80	±220
DB-4815SD3C	36-72	15	78	±15	±25	±100	81	±100

Suffix "C" means with control pin

Suffix "M" means with Metal Case

**NOTE**

1. Operation at no load condition will not damage the produce ; however, it will not meet all specifications.
2. One load is 25% to 100% load, the other load is 100% load, the output voltage variable rate is within  $\pm 5\%$ .
3. Measured with 20MHz bandwidth .
4. Test by minimal  $V_{in}$  and constant resistive load.
5. Test by normal  $V_{in}$  and 100%-25% load, 25% load step change .
6. Measured Input reflected ripple current with a simulated source inductance of 12uH and a source capacitor  $C_{in}(47\mu F, ESR < 1.0\Omega \text{ at } 100KHz)$ .
7. The Remote on/off control:  
 ON: open or high impedance  
 OFF: 3.0~6.0mA input current (via 1K)
8. Exceeding the absolute ratings of the unit could cause damage.  
 It's not allowed for continuous operating ratings.
9. 25% minimum loading is needed.
10. Input filter components are required to help meet conducted emission class A, which application refer to the EMI Filter of design & feature configuration.
11. An external filter capacitor is required if the module has to meet IEC61000-4-4 and IEC61000-4-5.  
 The filter capacitor ZimTec Electronics suggest: Nippon - chemi - con KY series, 220uF/100V.

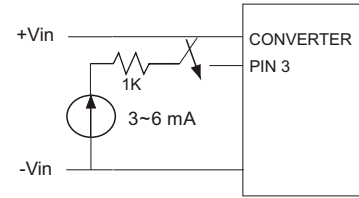

**TEST CONFIGURATIONS**

**Input Reflected Ripple Current Test Step**

Input reflected ripple current is measured through a source inductor  $L_{in}(12\mu H)$  and a source capacitor  $C_{in}(47\mu F, ESR < 1.0\Omega \text{ at } 100KHz)$  at nominal input and full load.

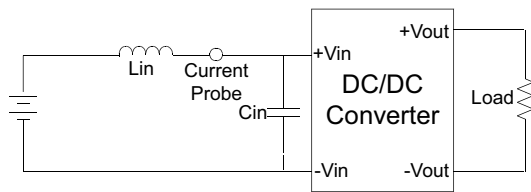

**Output Ripple & Noise Measurement Test**

The Scope measurement bandwidth is 20MHz.

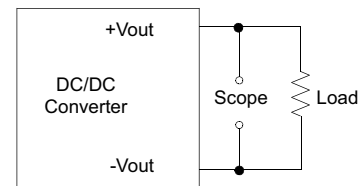

**EMI Filter**

Input filter components ( $C1, L$ ) are used to help meet conducted emissions requirement for the module. These components should be mounted as close as possible to the module; and all leads should be minimized to decrease radiated noise.

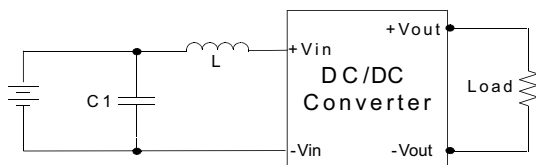

		C 1	L
DB-05XXXXXX		220 uF / 25 V	5.6 uH
DB-12XXXXXX	Single	100 uF / 100 V	18 uH
	Dual	1210, 2.2 uF / 100 V	
DB-24XXXXXX		1210, 10 uF / 35 V	18 uH
DB-48XXXXXX		100 uF / 100 V	56 uH

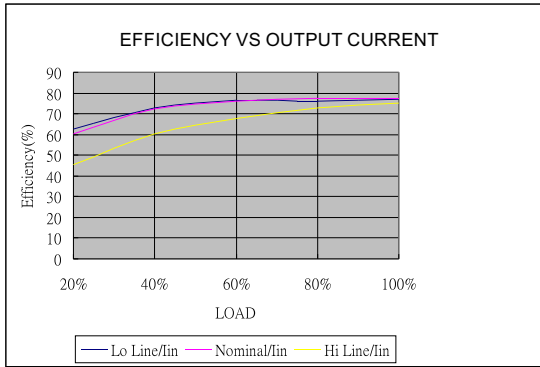

05 Models

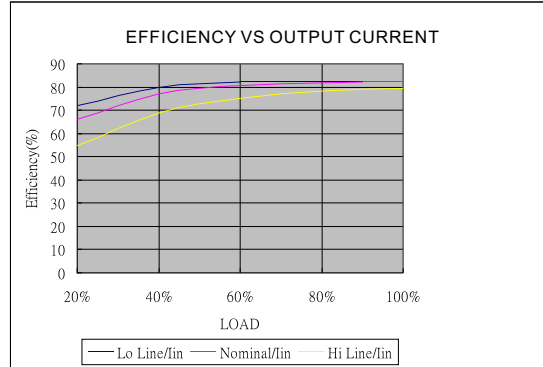

12 Models

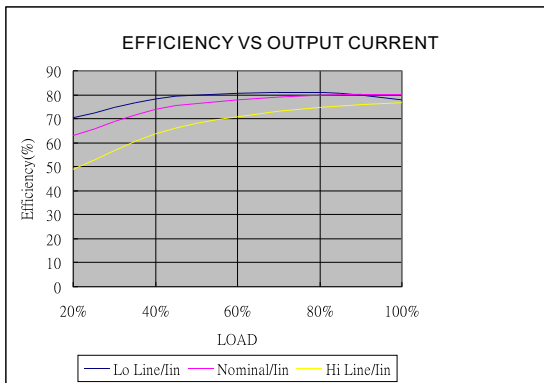

24 Models

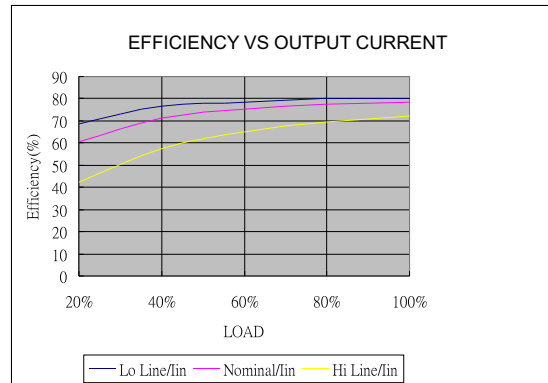

48 Models

**MECHANICAL SPECIFICATIONS**

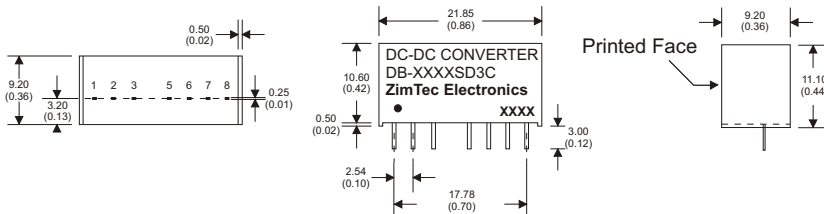

**8 Pin SIL Package**  
Non-Conductive Plastic

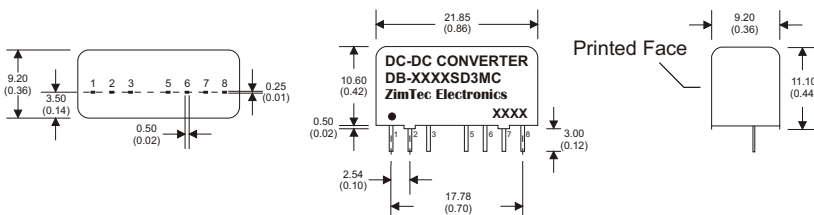

**8 Pin SIL Package**  
Nickel-Coated Copper

Notes: All dimensions are typical in millimeters ( inches ).  
 1. Pin diameter: 0.5 ±0.05 ( 0.02 ±0.002 )  
 2. Pin pitch and length tolerance: ±0.35 ( ±0.014 )  
 3. Case Tolerance: ±0.5 ( ±0.02 )

PIN CONNECTIONS		
PIN NUMBER	SINGLE+C	DUAL+C
1	-V Input	-V Input
2	+V Input	+V Input
3	Remote On/Off	Remote On/Off
5	N.C.	N.C.
6	+V Output	+V Output
7	-V Output	Common
8	N.C.	-V Output

PIN CONNECTIONS		
PIN NUMBER	SINGLE	DUAL
1	-V Input	-V Input
2	+V Input	+V Input
3	N.P.	N.C.
5	N.P.	N.C.
6	+V Output	+V Output
7	-V Output	Common
8	N.C.	-V Output