

# DB-6W Series

6W 2:1 Regulated Single & Dual output



## Features

- Highest Power Density In 8 Pin SIL Package
- Wide 2:1 Input Range
- Smallest Footprint 6W Converter
- No Minimum Load Required
- 1500 VDC Isolation , Up to 3000VDC
- Continuous Short Circuit Protection
- Efficiency up to 86%
- -40°C ~+ 65°C Operation Temperature Range
- Remote on/off Control (Optional)

The DB-6W series is a family of high performed 6W single & dual output DC-DC converters. These converters are built in non-conductive black plastic package in a 8-pin SIL miniature compact case with high performance features wide range devices operate over 2:1 input voltage range providing stable output voltage which is much smaller than package of DIL 24- Same power rating but only 43% of the traditional volume. Devices are encapsulated using flame retardant resin. Input voltages of 5, 12, 24, 48 with output voltage of 3.3, 5, 9, 12, 15, 24,  $\pm 5$ ,  $\pm 12$ ,  $\pm 15$  Vdc. Featuring new PFM construction, no minimum load required and precise 1% output voltage accuracy.

All specifications typical at Ta=25°C, nominal input voltage and full load unless otherwise specified

OUTPUT SPECIFICATIONS	
Voltage Accuracy	$\pm 1\%$
Maximum Output Current	See table
Line Regulation	$\pm 0.2\%$ max.
Load Regulation	Single & Dual (From 0% to 100% Load) $\pm 1.0\%$ max.
Cross Regulation (Dual Output) (1)	$\pm 5\%$
Ripple & Noise (20 MHz bandwidth)(2)	75mVpp,max.
Short Circuit Protection	Continuous (Automatic Recovery)
Temperature Coefficient	$\pm 0.02\%/^{\circ}\text{C}$
Capacitive Load(3)	See table
Transient Recovery Time (4)	500us, typ.
Transient Response Deviation(4)	$\pm 3\%$ , max.
	Output 3.3V&5V : $\pm 5\%$ , max.

INPUT SPECIFICATIONS	
Voltage Range	See table
Start up Time(Nominal Vin and constant resistive load)	30mS, typ
Max. Input Current	See table
No-Load Input Current	See table
Input Filter	Capacitor
Input Reflected Ripple Current(5)	30mApk-pk, typ
Remote on/off	
ON:	Open or high impedance
OFF:	2-4mA input current (via 1K $\Omega$ ).
Off stand by input current (Nominal Vin)	2.5mA, typ

GENERAL SPECIFICATIONS	
Efficiency	See table,typ.
I/O Isolation Voltage (60 sec)	1500~3000Vdc
I/O Isolation Capacity	50 pF,max.
I/O Isolation Resistance	1G Ohm,min.
Switching Frequency	100kHz,min.
Humidity	95%relH
Reliability Calculated MTBF (MIL-HDBK-217F)	>770 Khrs
Safety Standard(desig ned to meet)	IEC60950-1

PHYSICAL SPECIFICATIONS	
Case Material	Non conductive black plastic
Potting Material	Epoxy (UL94V-0 rated)
Pin Material	C5191R-H Solder-coated
Weight	4.8g,typ.
Dimensions	0.86"x0.36"x0.44"

ENVIRONMENT SPECIFICATIONS	
Operating Temperature	-40°C~65°C
Maximum Case Temperature	105°C
Storage Temperature	- 55°C~125°C
Cooling(6)	Nature Convection

ABSOLUTE MAXIMUM RATINGS(7)	
These are stress ratings. Exposure of devices to any of these conditions may adversely affect long-term reliability.	
Input Surge Voltage(100ms max)	
05 Models	15Vdc,max.
12 Models	25Vdc,max.
24 Models	50Vdc,max.
48 Models	100Vdc,max.
Soldering Temperature (1.5mm from case 10 sec. max.)	260°C, max.

EMC SPECIFICATIONS		
Radiated Emissions	EN55022	CLASS A
Conducted Emissions (8)	EN55022	CLASS A
ESD	IEC 61000-4-2	Perf. Criteria A
RS	IEC 61000-4-3	Perf. Criteria A
EFT (9)	IEC 61000-4-4	Perf. Criteria A
Surge (9)	IEC 61000-4-5	Perf. Criteria A
CS	IEC 61000-4-6	Perf. Criteria A
PFMF	IEC 61000-4-8	Perf. Criteria A

## DB - 6W 2:1 Regulated Single & Dual output

### PART NUMBER STRUCTURE

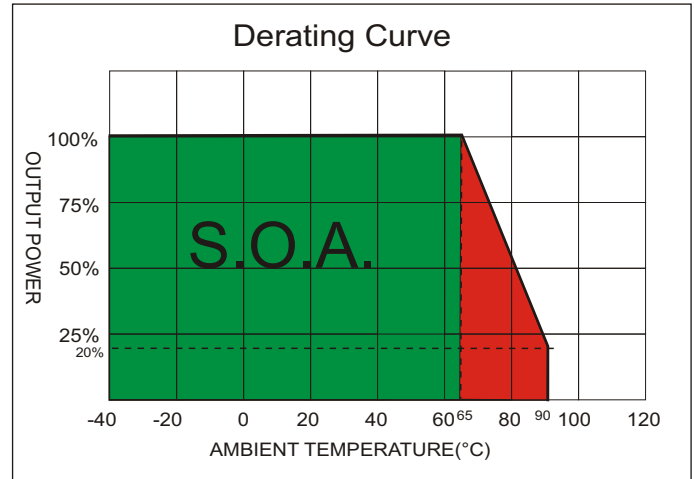
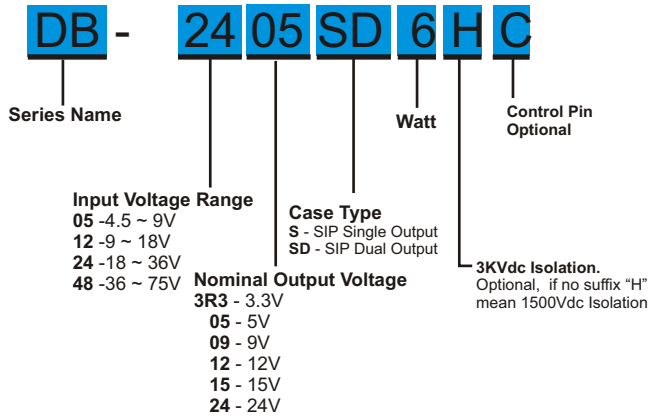

## MODEL SELECTION GUIDE

MODEL NUMBER	INPUT Voltage Range (Vdc)	INPUT Current		OUTPUT Voltage (Vdc)	OUTPUT Current		EFFICIENCY @FL(%)	Capacitor Load(uF)
		No-Load (mA)	Full Load (mA)		Min. load (mA)	Full load (mA)		
DB-053R3S6	4.5-9	105	1144	3.3	0	1300	75	6600uF
DB-0505S6	4.5-9	105	1519	5	0	1200	79	3300uF
DB-0509S6	4.5-9	105	1445	9	0	666	83	2000uF
DB-0512S6	4.5-9	105	1428	12	0	500	84	1600uF
DB-0515S6	4.5-9	105	1428	15	0	400	84	1400uF
DB-0524S6	4.5-9	105	1428	24	0	250	84	680uF
DB-0505SD6	4.5-9	105	1481	±5	0	±600	81	±2000uF
DB-0512SD6	4.5-9	105	1428	±12	0	±250	84	±900uF
DB-0515SD6	4.5-9	105	1428	±15	0	±200	84	±660uF
DB-123R3S6	9-18	55	470	3.3	0	1300	76	6600uF
DB-1205S6	9-18	55	602	5	0	1200	83	3300uF
DB-1209S6	9-18	55	595	9	0	666	84	2000uF
DB-1212S6	9-18	55	588	12	0	500	85	1600uF
DB-1215S6	9-18	55	588	15	0	400	85	1400uF
DB-1224S6	9-18	55	581	24	0	250	86	680uF
DB-1205SD6	9-18	55	609	±5	0	±600	82	±2000uF
DB-1212SD6	9-18	55	595	±12	0	±250	84	±900uF
DB-1215SD6	9-18	55	581	±15	0	±200	86	±660uF
DB-243R3S6	18-36	30	229	3.3	0	1300	78	6600uF
DB-2405S6	18-36	30	301	5	0	1200	83	3300uF
DB-2409S6	18-36	30	294	9	0	666	85	2000uF
DB-2412S6	18-36	30	294	12	0	500	85	1600uF
DB-2415S6	18-36	30	287	15	0	400	87	1400uF
DB-2424S6	18-36	30	287	24	0	250	87	680uF
DB-2405SD6	18-36	30	304	±5	0	±600	82	±2000uF
DB-2412SD6	18-36	30	297	±12	0	±250	84	±900uF
DB-2415SD6	18-36	30	297	±15	0	±200	84	±660uF
DB-483R3S6	36-75	15	117	3.3	0	1300	76	6600uF
DB-4805S6	36-75	15	156	5	0	1200	80	3300uF
DB-4809S6	36-75	15	147	9	0	666	85	2000uF
DB-4812S6	36-75	15	149	12	0	500	84	1600uF
DB-4815S6	36-75	15	145	15	0	400	86	1400uF
DB-4824S6	36-75	15	148	24	0	250	84	680uF
DB-4805SD6	36-75	15	152	±5	0	±600	82	±2000uF
DB-4812SD6	36-75	15	147	±12	0	±250	85	±900uF
DB-4815SD6	36-75	15	147	±15	0	±200	85	±660uF

Suffix "H" means 3KVdc isolation

Suffix "C" means with control pin

The models listed above are just for standard type. If you need the special specification product, please contact our service member by E-Mail presented in short form cover at [info@zimtec-electronics.de](mailto:info@zimtec-electronics.de)

**NOTE**

1. One load is 25% to 100% load, the other load is 100% load, the output voltage variable rate is within  $\pm 5\%$ .
2. Measured with a 0.1uF ceramic capacitor.
3. Test by minimal Vin and constant resistive load.
4. Test by normal Vin and 100%-25% load, 25% load step change.
5. Measured Input reflected ripple current with a simulated source inductance of 12uH and a source capacitor Cin(47uF, ESR<1.0Ω at 100KHz).
6. "Nature Convection" is usually about 30-65 LFM but is not equal to still air (0 LFM).
7. Exceeding the absolute ratings of the unit could cause damage. It's not allowed for continuous operating ratings
8. Input filter components are required to help meet conducted emission class A, which application refer to the EMI Filter of design & feature configuration.
9. An external filter capacitor is required if the module has to meet IEC61000-4-4 and IEC61000-4-5.  
The filter capacitor ZimTec Electronics GmbH suggest: Nippon - chemi - con KY series, 330uF/100V.

**TEST CONFIGURATIONS**

**Input Reflected Ripple Current Test Step**

Input reflected ripple current is measured through a source inductor Lin(12uH) and a source capacitor Cin(47uF, ESR<1.0Ω at 100KHz) at nominal input and full load.

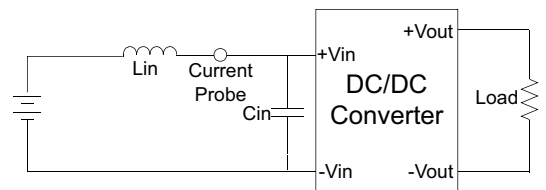

**Output Ripple & Noise Measurement Test**

Use a capacitor Cout(0.1uF) measurement. The Scope measurement bandwidth is 0-20MHz.

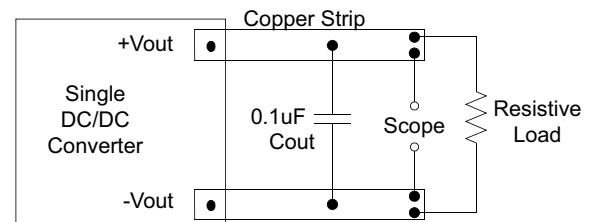

**EMI Filter**

Input filter components (C1,C2,C3,C4,C5, L) are used to help meet conducted emissions requirement for the module. These components should be mounted as close as possible to the module; and all leads should be minimized to decrease radiated noise.

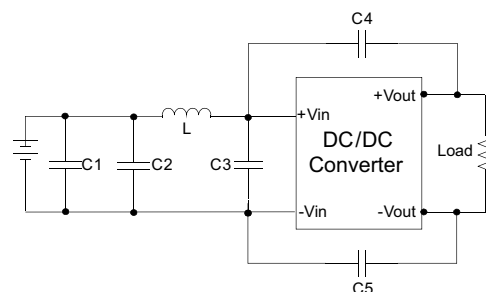

	C1	C2 & C3	L	C4 & C5
DB-05YYO6	Electrolytic capacitor 220uF/100V	MLCC 22uF/25V	10uH	MLCC 220pF/3KV
DB-12YYO6		MLCC 10uF/50V	10uH	MLCC 220pF/3KV
DB-24YYO6		MLCC 10uF/50V	10uH	MLCC 220pF/3KV
DB-48YYO6		MLCC 2.2uF/100V	15uH	MLCC 220pF/3KV

**MECHANICAL SPECIFICATIONS**

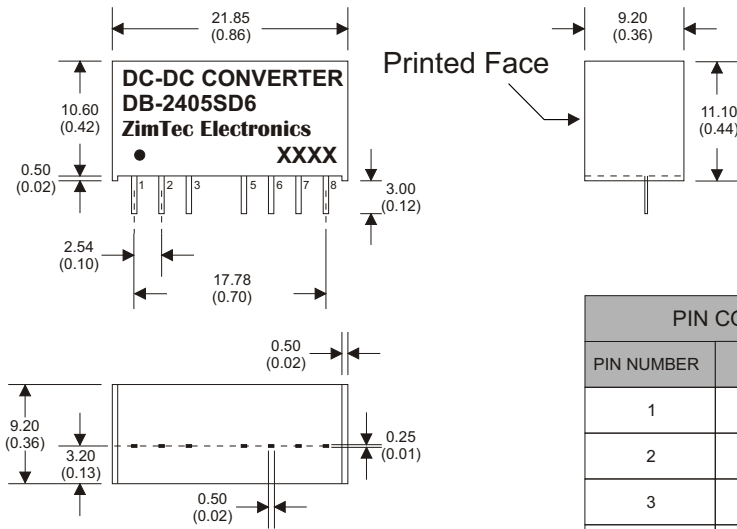

**8 Pin SIL Package**

- Notes : All dimensions are typical in millimeters ( inches ).
1. Pin diameter: 0.5±0.05 ( 0.02±0.002 )
  2. Pin pitch and length tolerance: ±0.35 ( ±0.014 )
  3. Pin to case tolerance: ±0.5 ( ±0.02 )
  4. Case Tolerance: ±0.5 ( ±0.02 )
  5. Stand-off tolerance: ±0.1 ( ±0.004 )

PIN CONNECTIONS		
PIN NUMBER	SINGLE	DUAL
1	-V Input	-V Input
2	+V Input	+V Input
3	N.P.	N.C.
5	N.P.	N.C.
6	+V Output	+V Output
7	-V Output	Common
8	N.C.	-V Output

PIN CONNECTIONS		
PIN NUMBER	SINGLE + C	DUAL + C
1	-V Input	-V Input
2	+V Input	+V Input
3	Remote On/Off	Remote On/Off
5	N.C.	N.C.
6	+V Output	+V Output
7	-V Output	Common
8	N.C.	-V Output