

SBA 0804,1206 SERIES

SURFACE-MOUNT MULTI-LAYER CHIP ARRAY BEADS

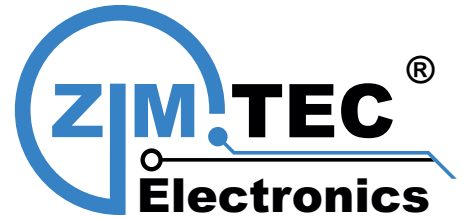

FEATURES:

- Multilayer structure
- Closed magnetic circuit
- Avoids crosstalk
- Excellent magnetic shield
- Excellent solderability
- High reliability
- EMI/RFI suppression
- 20% impedance tolerance

COMMON APPLICATIONS:

- Cellular Phones
- Mobil Radios
- Cordless Telephones
- Modems
- Global Positioning Systems
- Wireless Communications Equipment
- Network Systems
- Computer Products

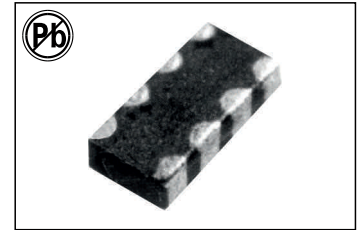

SIZE CHART: Sizes shown are in mm and (inches)

Part Number	IMPEDANCE Ω @T 100 MHz	DCR (Ω) Max	IDC Max mA	Part Number	IMPEDANCE (Ω) @T 100 MHz	DRC (Ω) Max	IDC Max mA
SBA-0804-2-310	31	0.20	50	SBA-1206-2-310	31	0.10	500
SBA-0804-2-600	60	0.35	50	SBA-1206-2-600	60	0.15	500
SBA-0804-2-121	120	0.40	50	SBA-1206-2-121	120	0.20	500
SBA-0804-2-151	150	0.40	50	SBA-1206-2-151	150	0.20	500
SBA-0804-2-221	220	0.50	50	SBA-1206-2-221	220	0.30	300
SBA-0804-2-301	300	0.60	50	SBA-1206-2-301	300	0.40	250
SBA-0804-2-601	600	0.70	50	SBA-1206-2-601	600	0.50	200
SBA-0804-2-801	800	0.80	50	SBA-1206-2-801	800	0.65	100
SBA-0804-2-102	1000	0.90	50	SBA-1206-2-102	1000	0.80	50
SBA-0804-2-122	1200	1.00	50	SBA-1206-2-122	1200	0.90	50
SBA-0804-4-310	30	0.20	50	SBA-1206-4-310	30	0.10	500
SBA-0804-4-600	60	0.35	50	SBA-1206-4-600	60	0.15	500
SBA-0804-4-121	120	0.40	50	SBA-1206-4-121	120	0.20	500
SBA-0804-4-151	150	0.40	50	SBA-1206-4-151	150	0.20	500
SBA-0804-4-221	220	0.50	50	SBA-1206-4-221	220	0.30	300
SBA-0804-4-301	300	0.60	50	SBA-1206-4-301	300	0.40	250
SBA-0804-4-601	600	0.70	50	SBA-1206-4-601	600	0.50	200
SBA-0804-4-801	800	0.80	50	SBA-1206-4-801	800	0.65	100
SBA-0804-4-102	1000	0.90	50	SBA-1206-4-102	1000	0.80	50
SBA-0804-4-122	1200	1.00	50	SBA-1206-4-122	1200	0.90	50

TECHNICAL INFORMATION & ELECTRICAL CHARACTERISTICS

- Testing: Impedance vs. Frequency: HP 4195A
- Solderability: 90% of the terminal electrode shall be covered
Preheat: @ 260 °C \pm 5 °C for 60 seconds
Flux: Rosin, Dip for 10 seconds \pm 1 second
- Thermal Shock: Impedance shall within \pm 20% of initial value when temperature is -25 °C and +85 °C for 30 minutes for each 50 cycles
- Operating Temperature: -25 °C to +85 °C
- Storage Temperature: -25 °C to +85 °C

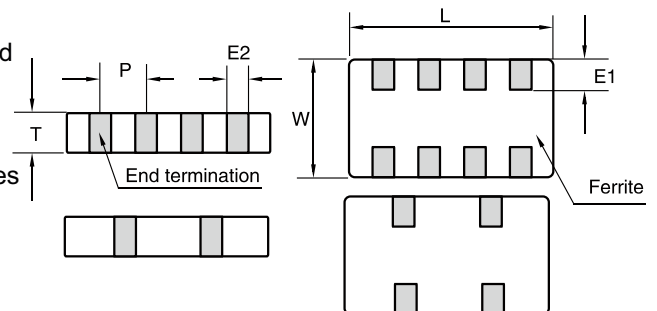

CODE	L	W	T	E1	E2	P
2010 (0804)	2.0 \pm 0.15 (0.079 \pm 0.006)	1.0 \pm 0.15 (0.039 \pm 0.006)	0.5 \pm 0.1 (0.020 \pm 0.004)	2.0 _{+0.15-0.1} (0.079 _{+0.006-0.004})	2.0 \pm 0.15 (0.079 \pm 0.006)	2.0 \pm 0.15 (0.079 \pm 0.006)
3216 (1206)	3.2 \pm 0.2 (0.126 \pm 0.008)	1.660.2 (0.063 \pm 0.008)	0.9 \pm 0.1 (0.031 \pm 0.004)	3.2 \pm 0.2 (0.126 \pm 0.008)	0.3 \pm 0.2 (0.012 \pm 0.008)	0.8 \pm 0.1 (0.031 \pm 0.004)

Note: All specifications subject to change without notice.

ZimTec Electronics GmbH

Franz-Mehring-Weg 2, 39606 Osterburg, Germany

E-mail : info@zimtec-electronics.de

Web : www.zimtec-electronics.de

Last Update : 01.Jun.2015